

TIPS ON POULTRY RAISING INTRODUCTION

Chicken broiler and egg production are the most progressive animal enterprises in the Philippines today. The poultry industry in fact began as a backyard enterprise but has shifted to the formation of very large integrated contract farming operations.

The growth of the poultry industry in the Philippines has indeed been impressive but its problems including inefficient management and the prevalence of many destructive poultry diseases and parasites cannot be ignored.

This manual provides technology and management know-how for poultry raising which we hope present poultry raisers and prospective poultry producers may find useful in effectively managing their poultry farms and also help them realize substantial financial returns from their enterprises in this period of high production cost inputs.

CHICKEN BREEDS/STOCK TO RAISE

The following can be used as a guide in selecting the foundation stock to raise:

- Stock should only be purchased from a reliable hatchery or franchised dealer where the parent stocks are well-housed and well-managed.
- The kind of stock to buy depends upon the purpose for which it is going to be raised.
- Chicks should be free from diseases and deformities.
- Chicks should have uniform size and color and in the case of broiler chicks should not be less than 33 grams at day-old.
- For a start, a popular strain raised in the community can be selected as it is an indication of the bird's good performance under existing farm conditions.
- For broilers, choose those that have high livability and are fast growers.
- For layers, choose those that have good egg size, high egg production and long productive life.

The following are the strains of day old chicks that are now commercially available:

Egg Type& Meat Type	Sources of Stock
1. Arbor Acres	San Miguel Foods Inc. Population Centre Building Nichols Interchange, Makati City Tel. No.: 878-4042
2. Babcock	Sarmiento Agricultural Devt. Corporation Sarmiento Bldg. II, Pasong Tamo Ext. Makati City Tel. No.: 816-7461
3. Lohman Console Farms	Batuhan, San Miguel, Bulacan 2 Samat St., Quezon City Tel. No.: 731-1842
4. Starbro	Universal Robina Farms CFC Bldg. Bo. Ugong, Pasig Metro Manila Tel. No.: 671 -8303
5. Avian	JAKA 211 Pasong Tamo Makati City Tel. Nos.: 844-7209/845-0236
6. Avian Swift (RFM)	2nd Floor RFM Bldg. Pioneer St., Mandaluyong Tel. No.: 631-8101
7. Pilch -Dekalb	General Milling Corporation E. Rodriguez Avenue Pasig, Metro Manila Tel. Nos.: 8195451/671-9943
8. Avian/Hubbard	Tyson Agro Ventures 179 Mariano Ponce Kaloocan City Tel. No.: 366-5213

The following space requirements may serve as guide:

Layers

- | | |
|-----------------------------|-------------------|
| a. Day-old to four weeks | 15 sq.in./chick |
| b. Four to eight weeks | 30 sq.in./chick |
| c. Nine weeks to laying age | 50-60 sq.cm./bird |

Broilers

- | | |
|---------------------------|------------------|
| a. Day-old to three weeks | 0.3 sq.ft./chick |
| b. 3 weeks to 4 weeks | 0.5 sq.ft./chick |
| c. 5 weeks to market age | 1.0 sq.ft./bird |

Recommended Minimum Feeding Space Requirements:

- | | |
|-------------------------------|-------------------|
| a. Day-old to 4 weeks | 2.5 to 5 cm./bird |
| b. 4 weeks to 8 weeks | 5 to 6.5 cm./bird |
| c. 9 weeks to near laying age | 7.5 to 9 cm./bird |
| d. Layers | 10 cm./bird |

Recommended Minimum Watering Space Requirements

- | | |
|-------------------------------|---|
| a. Day-old to 4 weeks | 0.5 cm./bird or two 1-gal. drinking fountains/100 birds |
| b. 4 weeks to 8 weeks | 0.6 to 1 cm./bird or two 2-gal drinking fountains/100 birds |
| c. 9 weeks to near laying age | 1 to 2 cm./bird or four 2-gal drinking fountains/100 birds |
| d. layers | 2 to 2.5 cm/bird or six 2-gal drinking fountains/ 100 birds |

Recommended Floor Type

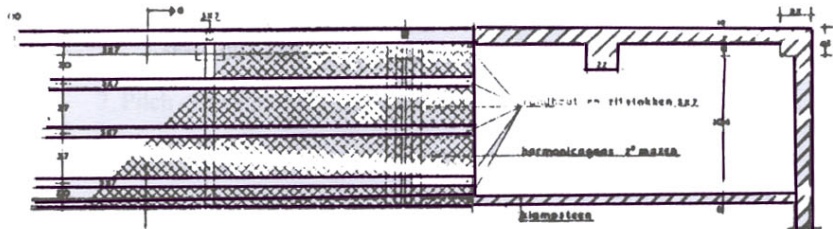
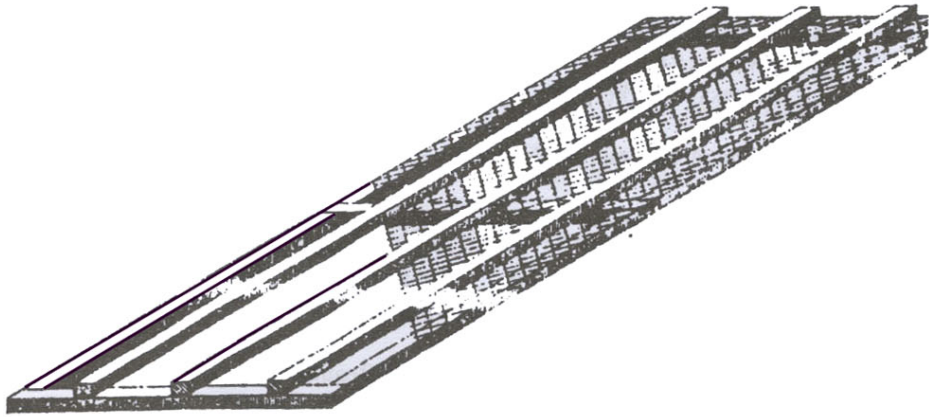
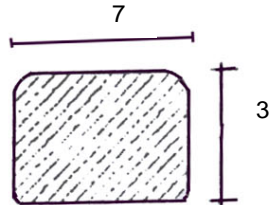

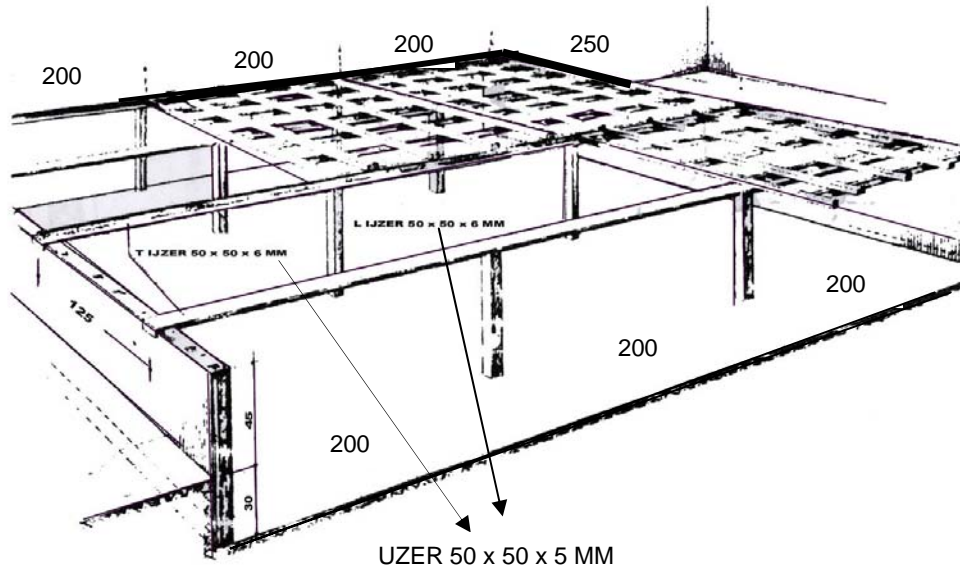

HOPPER: FUNCTION

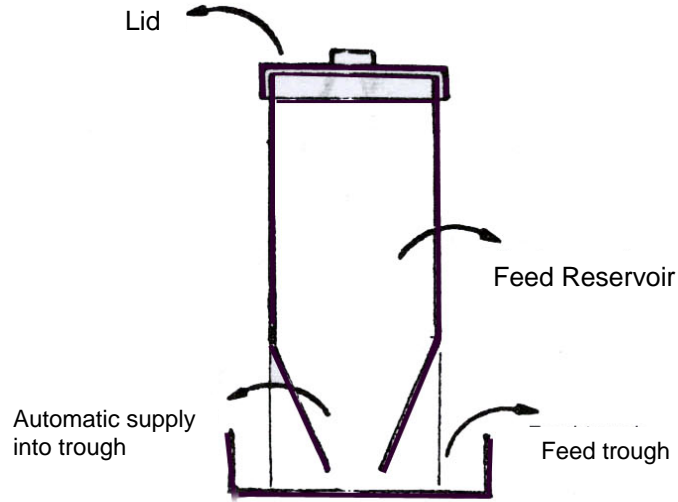

DRY MASH FEED TROUGH



DRY MASH FEED TROUGH:
FUNCTION OF LIP

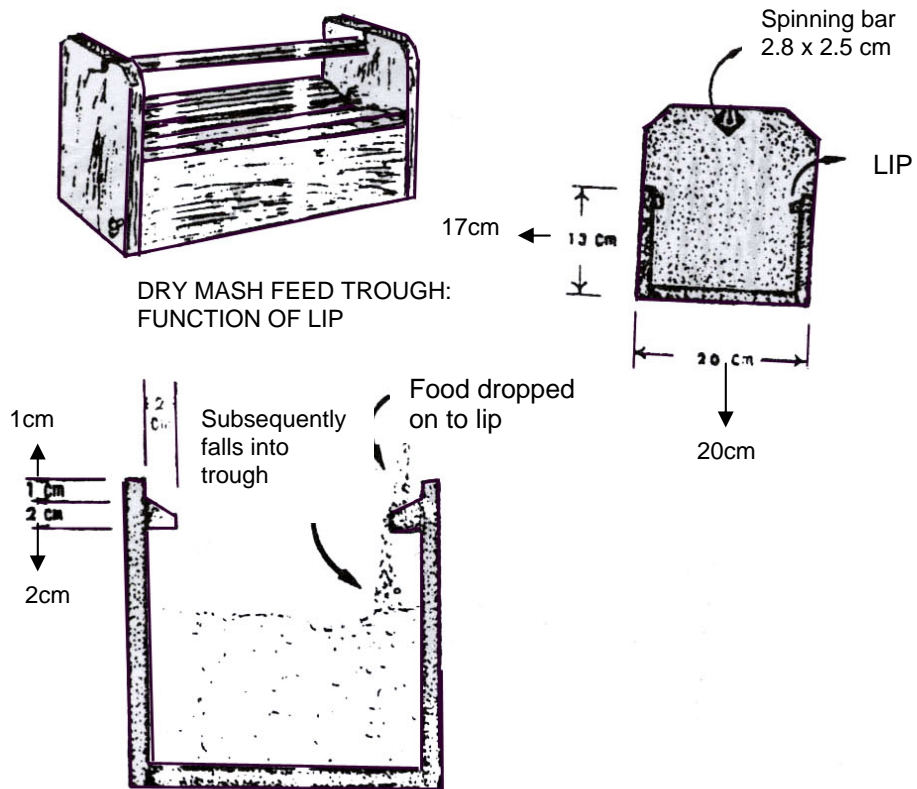

GRIP HOPPER, ALSO SUITABLE FOR DRY MASH

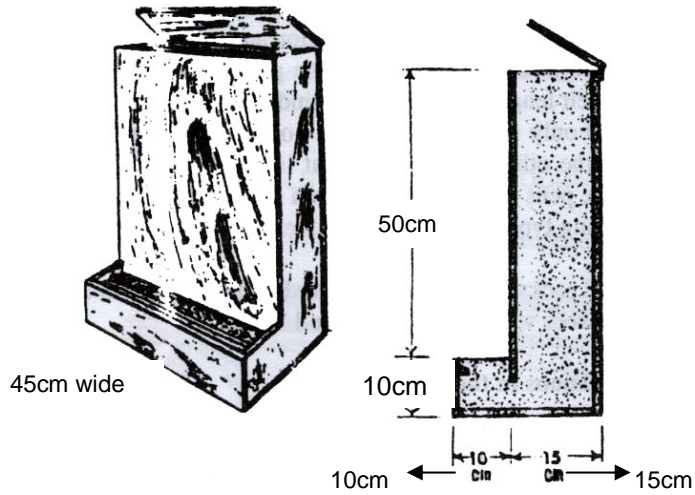

GRIP HOPPER

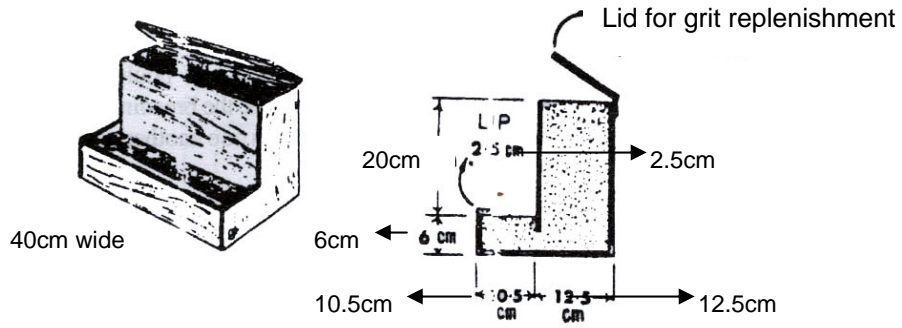

HANGING FEED TROUGH
Trough 120cm long providing
double-sided feeding

Lips along sides reduce food wastage

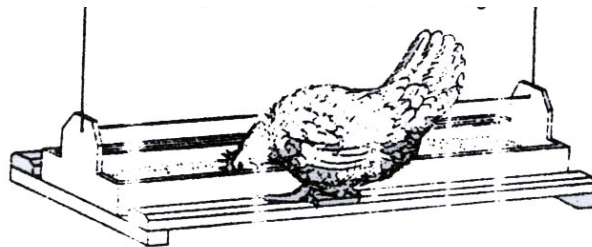

Base and total height, 25cm
Height of sides, 12cm
Perch fro trough, 10 cm

2. Environmental Factors

Birds must be protected from poor ventilation and extremes in temperature. When the land dimension allows it, the poultry houses should be constructed with their length parallel to the wind direction. This setup will expose to the wind only the southern or the northernmost portion of the houses. If it were the other way around, that is, the length of the house facing south, all the pens with the birds therein would be exposed to draft and heavy rain during typhoons and bad weather.

Discarded feed sacks when available, can be utilized as wind and sun breakers. Planting trees will also serve as windbreaks.

3. Sanitary Provisions in the Poultry House

In planning the construction, due consideration should be given to facilitate cleaning of the poultry house. Thus, in the case of brooders, the floors, sides and partitions should be detachables. This will permit their removal for thorough cleaning and disinfection after every batch. There should have good water drainage from the house site.

Due consideration should be given to the aspect of poultry disease prevention and control. When there is ample land area, the breeding, growing and laying houses should be reasonably spaced from one another as a health safety measure.

4. Provision for Easy Expansion

Consider future expansion plans. The buildings that are to be constructed should consider the setting up of additional new houses that may be needed later.

5. Economy of Construction

Poultry houses need not be very expensive to construct. There are many locally available cheap materials that are very common to poultry raisers like bamboo, coconut trunks, cogon, nipa and rattan. The rule is to use local materials that are readily available.

HOUSING EQUIPMENT

1. Feeding troughs or feeders

Feeders can be placed inside or along the front of the cages. When making feeders, consider the ease in cleaning and avoidance of feed spillage. Feed spillage may be avoided by placing a metal or wooden strip along the inner mouth of the feeding trough.

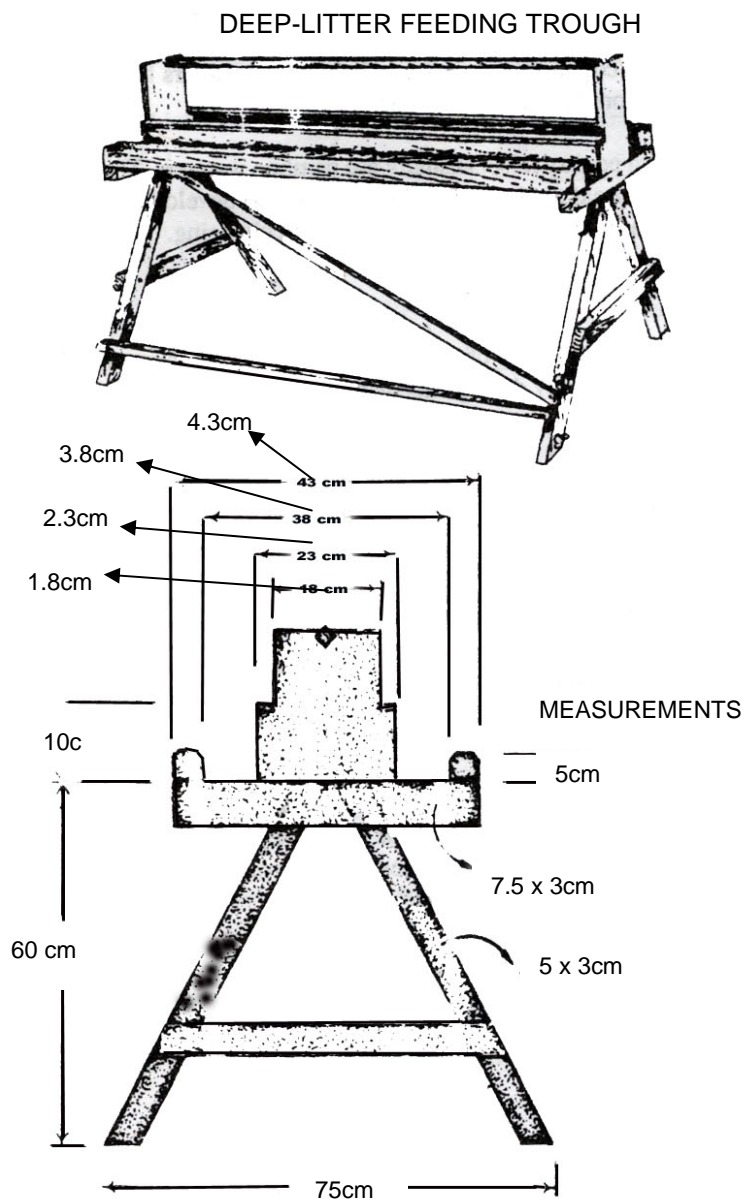

2. Waterers

To facilitate cleaning, the shape and size of the waterers should be semi-circular, fairly wide and supported by an adjustable bracket to permit easier adjustment. It may have a removal stopper at the drainage end to allow for easier cleaning.

For chicks, the waterers are usually one-gallon plastic jars.

The most common waterers are the plastic waterers because they do not rust therefore they will last longer.

Backyard poultry raisers usually use bamboo waterers. They are cheap but there is a great tendency for slime (lumot) to develop and oftentimes they do not last very long. They need constant changing.

3. Portable Catching Panels

This is usually made of either bamboo, wood or wire frames. This device comes in handy during vaccination.

4. Feed Carts

In a well-planned poultry house with cemented service alleys, the feed cart is a handy piece of equipment which can reduce the number of hours spent in feeding the chickens. It makes the feeding less laborious and tiresome. In the absence of a feed cart a wheelbarrow will do.

POULTRY MANAGEMENT

REARING OF THE DAY-OLD CHICKS

Brooding is essential for the chicks. Brooding is the process of supplying artificial heat to the chicks from the time they are taken out from the incubators up to the time their bodies can control their heat requirements and they are covered with feathers.

The following are the basic requirements for brooding day-old chicks:

1. Sufficient Heat

- * Provide sufficient artificial heat to keep chicks comfortably warm during the day or night. Avoid abrupt changes in brooder temperature during the first-two weeks of life.

* The following set of temperatures have been found to be ideal for brooding under Philippine conditions. Use this as a guide only.

Age of Chicks (weeks)	Brooding Temperature (⁰ C)
0-1	32.2 – 35.0 (90-95 F)
1-2	29.4 – 32.2 (85-90 F)
2-4	26.7 – 29.4 (80-85 F)
Above 4 weeks	Remove the supply of heat

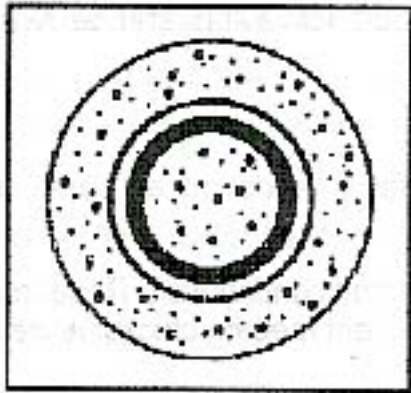

Fig.1 The chicks feel comfortable and evenly distributed around the hoover when the temperature is right

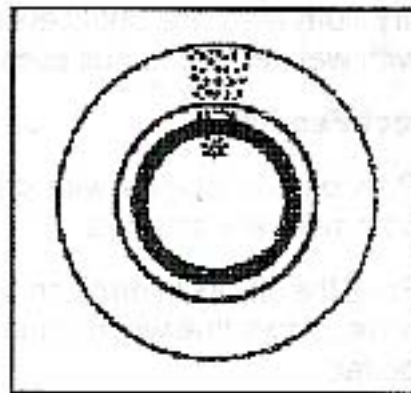

Fig.2 There is draft when the chicks wedge behind the hoover

The behavior of the day-old chicks in the brooder can be used as guideline for the correct brooding temperature. When the temperature is hot, the chicks will pant, spread out their wings, eat less and remain inactive, move away from the source of heat and stay close to the edges of tile brooder. When temperature is low, the chicks will crowd under the heater, pile up and make known their comfort loud chirping.

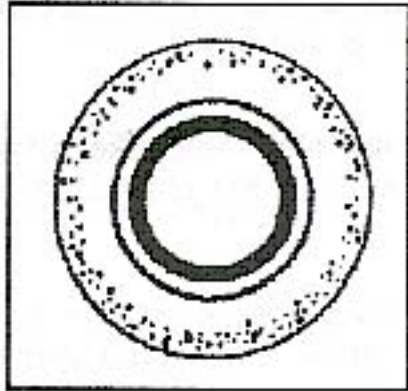

Fig.1 It is too hot when the chicks open their wings and move away from the heat source

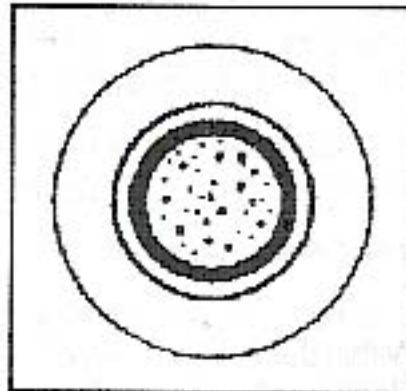

Fig.2 It is too cold when the chicks chirp and pile under the heat source

2. Adequate Light and Ventilation

- * A well-lighted brooder attracts and encourages the chicks to start feeding,
- * Provide sufficient ventilation to supply plenty of oxygen and facilitate the removal of carbon dioxide and excess moisture. When there is not enough ventilation, the chicks will not only be weak and in poor condition but will also be more predisposed to respiratory diseases,

3. Ample space to avoid overcrowding

- * Provide the brooder with enough space to avoid overcrowding which leads to poorly developed chicks, high mortality as well as harmful vices like toe picking, feather picking or cannibalism.

4. Healthy stocks

- * Select only healthy chicks, which can be easily recognized by their dry, fluffy feathers, bright eyes and alert active appearance. Avoid chicks with wet vents and dull eyes.

5. Correct Feeding

- * Provide the chicks with good quality feeds either home grown or commercially sourced.
- * Feed the chicks intermittently rather than continuously. Research studies have shown that when using intermittent feeding chicks utilize nutrients better.
- * Do not allow feed troughs to go empty longer than one to two hours.

6. Proper Sanitation

- * Cleanliness and dryness of the brooding quarters will prevent contamination of the chicks from parasites and diseases which may be carried by previous brooded chicks.

7. Regularity of Care and Management

- * Environment should be kept as uniform as possible. Sudden changes in surroundings cause a certain degree of stress or insecurity. Such examples are removal of brooder canopy and slamming doors of brooder houses or the presence of drafts.
- * It is advisable that a regular caretaker feed the chickens following a definite schedule during the first 3 weeks of the chick's life.

8. Environmental Control

Optimum house temperature for laying birds is between 18°C-29°C. Within this range, maintain a uniform house temperature when possible. Flock health and performance are highly dependent on temperature control and good ventilation. Fans may aid in keeping the birds more comfortable during hot summer months. In environmentally controlled houses be sure to provide for adequate air movement especially during hot weather. Evaporative cooling may be used to lower the house temperature.

- * Make sure that feeds and fresh water are always available. Vitamins, minerals and antibiotic supplements may be added to the drinking water during the first few days. Consult your feed dealer.
- * Always check the chicks at night before going to sleep.

- * After 7 to 10 days the brooder floor mats can be removed.
- * More feeders and waterers should be made available as the chicks grow.
- * Vaccination against avian pest is a good measure to prevent the outbreak of the disease.
- * All weak, deformed and sickly chicks should be culled right away and properly disposed of.
- * The immediate burning or burying of dead birds is an important part of a good sanitation program. Use an incinerator if dealing with large numbers or bury them in the ground right away. Do not expose to flies or rats.

REARING OF THE GROWING STOCK

- * Broilers are marketed when they reach 45-60 days of age depending on strain.
- * For the egg type, chicks are transferred to the growing houses or pens at 6-8 weeks old. They are kept in these quarters until they are 16-18 weeks old at which time then they are transferred to the laying house.
- * Birds are given anti-stress drugs, either in the feed or in the drinking water 2-5 days before and after they are transferred to the growing houses.
- * Thoroughly clean and disinfect the growing houses prior to the transfer of the growing stock. Transfer birds only during good weather.
- * During hot summer days, the appetite of the birds diminishes but this may be sufficiently restored by wet mash feeding or by taking appropriate measures to lower house temperature like spraying, misting or sprinkling the roofing with water.
- * Provide clean fresh drinking water at all times.

MANAGEMENT OF THE LAYER FLOCK

- * Pullets are transferred to the laying house at the age of 16-18 weeks or at least 3 weeks before the onset of egg production.

- * A few days before and after the transfer, the bird's ration should be fortified with antibiotics and vitamins to minimize or counteract the effects of stress.
- * Cull those birds that show little or no promise of becoming potential layers.
- * Birds will start laying when they are 20-22 weeks old. Generally, pullets reach maximum egg production when they are between 30-36 weeks old, after which egg production tends to decline and then levels off.
- * After the first year of laying, the layers undergo a physiological process called molting. Early molters are poor layers while late molters are good ones.
- * During the second year of production, the layers usually average about 10 to 20 percent fewer eggs as compared to the first year but the eggs are bigger.
- * Provide layers with calcium supplements like limestone and ground oyster shell and insoluble grit.

TIPS ON LAYER MANAGEMENT ON HOT CLIMATE

Ventilation

1. Air movement around birds at floor level has a beneficial cooling effect. In shade houses, take full advantage of natural breezes using paddles or circulating fans in periods of still weather and particularly during the heat of the day. In controlled environment houses, use inlets with moveable louvres that can direct moving air directly on to the birds at floor level.
2. In controlled environment houses, over-ventilate during the cool part of the day in order to cool down the whole house. Birds experiencing a cool period each day are better able to withstand hotter-periods with no adverse effects on performance.

Floor Space

1. Provide birds with up to 100% (depending on severity of conditions) more floor space than is recommended for temperate climates. Three birds per square meter is an absolute maximum. In controlled environment houses, rearing males with females makes the most economic use of expensive floor space.

Litter Management

1. Maintain only a very shallow layer of litter on concrete *floors*. This will maximize any cooling effect that the concrete floor may have on the birds through absorption of body heat.
2. Dry, dusty litter can cause severe irritation and damage to the eyes of chickens. Avoid dustiness by sprinkling water generously on litter at regular intervals. This spraying can, during extremely hot, dry spells, be advantageously extended to the birds themselves and the feed.

Water Supplies

1. Whenever possible, use water supply such as well which provides cool water. Water consumption can double in very hot weather.
2. Bury or insulate water pipes to maintain the original coolness.
3. Supply troughs in which breeders may dip their combs and wattles so that evaporation of water cool the blood supply in the combs and wattles.
4. In extremely hot weather, when water consumption may be doubled to prevent heat prostration, do not place drugs or other substances in the water that might decrease its palatability and, therefore, its uptake. The distribution of waterers should be such as to minimize the distance any bird has to move in order to drink; ideally, both feed and water should be distributed so that no bird has to move more than 1 1/2 meters to get its requirements.

Lighting

1. In shade houses, natural daylight must be supplemented with artificial lighting in order to obtain desirable lighting patterns that are necessary to adequately control sexual maturity. A constant or decreasing lighting pattern during rearing is essential to prevent too early sexual maturity. An increasing or constant light pattern is necessary after 22-24 weeks of age.

Egg Handling

1. Supply at least one nest per four females. Ensure free circulation of air round the nest areas to discourage broodiness.

2. Collect eggs more regularly than in temperate areas and transfer immediately to the egg cooling room which should be located on the farm site. Transport eggs to the hatchery in an insulated van.
3. Practice daily fumigation of eggs.

Nutrition

1. In hot climates, poor production, small egg size, and thin shells are generally the result of an inadequate daily intake of the required nutrients.
2. Where feed consumption is lowered merely by depression of the appetite and because of high temperatures during the period of bird activity, there will be an inadequate intake of *ALL* nutrients. This can be corrected by allowing the feeding activity to occur during the cool part of the day, when appetite is stimulated. Additionally, if facilities allow, advantage can be gained by feeding damped or wet mash, as can the substitution of mash by crumbs or pellets.
3. Generally, in hot climates, the energy requirements of the hen are much reduced; because she eats to meet only her energy requirements, this results in an inadequate daily intake of protein, vitamins and minerals. In this situation, the correct daily intake of nutrients can only be achieved by correct feed formulation based upon a denser ration in which particular attention should be given to increasing vitamin levels well above temperate climate levels.
4. The correct formulation of feed depends upon local conditions. It requires knowledge of the relationship between energy content of the feed and the amount of feed consumed daily. With correct formulation the latter will contain the correct daily allowance of protein, vitamins and minerals. Some vitamin supplementation can be done via the water and a continuous level of vitamin supplementation is virtually essential during all periods of heat stress.
5. Feed intake is the main method of controlling sexual maturity in open houses and very careful attention must be given to controlling quantities very often to levels much below those used in temperate areas.
6. Where intake levels are severely controlled, check weighing of the birds is absolutely vital. It is also essential to ensure proper ration formulation particularly in respect of any drug inclusions such as coccidiostats.

LAYING NEST STRUCTURE

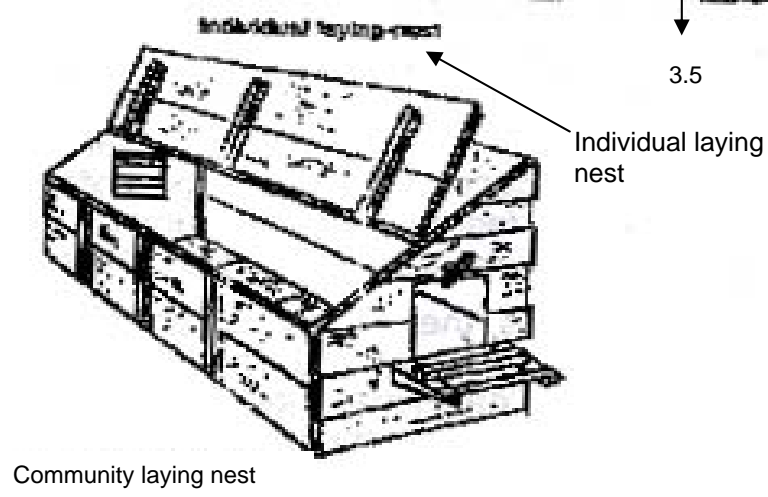
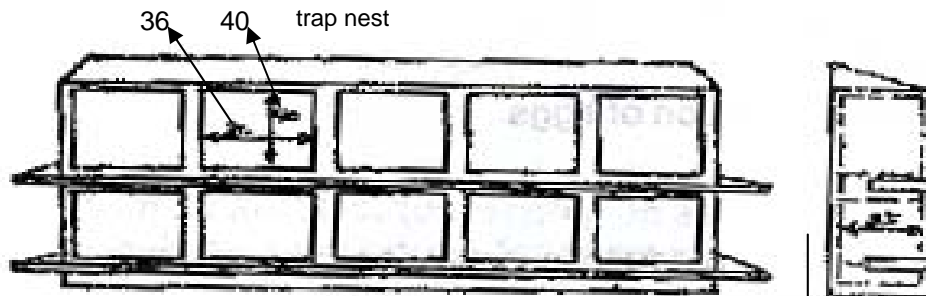
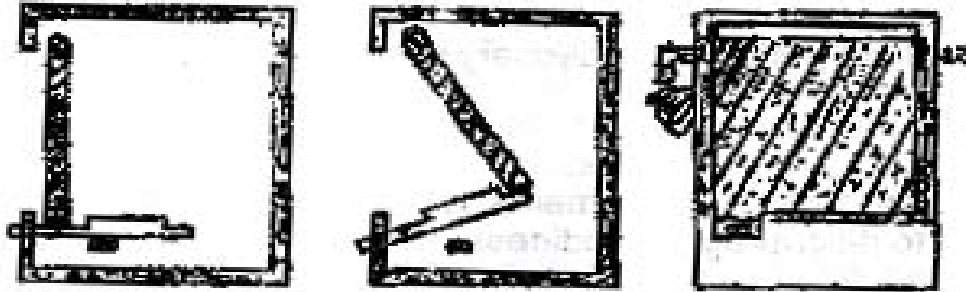

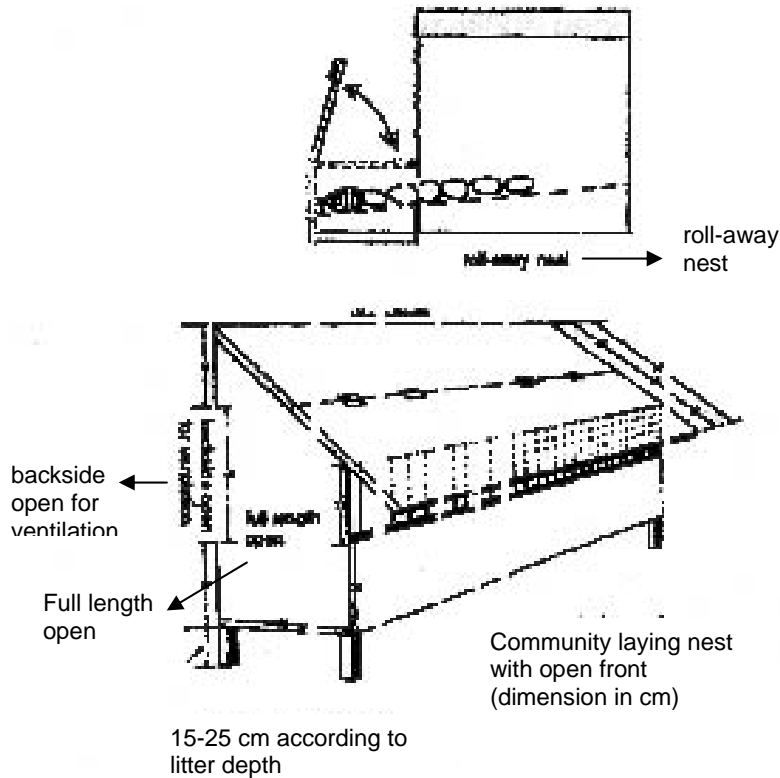

CULLING POOR LAYERS

Consider the following pointers in culling poor layers:

Characteristics	Description
Comb, wattle, earlobes	Small pale, cold, shrunken and dry.
Pubic bones (2 small bones extending along the sides of the vent)	Close together, only one finger can be placed between them, thick and hard.
Vent	Small, dry puckered and round.
Abdomen	Hard with thick skin, contracted.

Span (distance between end of breast bone and ends of pubic bones)

About 1-2 fingers in width.

Pigmentation (yellow beak and shanks)

Remains yellow even after months in laying pen

FEEDING MANAGEMENT

BROLER/MEAT TYPE

- ◆ Broiler commercial rations are fed to the birds during the first 5 weeks and from then on are replaced by the broiler-finisher ration.
- ◆ All purpose of straight broiler ration is fed from the start to the marketing age of eight weeks.
- ◆ Commercial broiler feeds contain additives considered to be growth promoting substances. Feed additives make the production of broiler profitable and help broiler farmers control diseases. Purchase feeds from feed dealers nearest your place.

LAYER/EGG TYPE

- ◆ Starter mash is given to chicks from day old to 8-10 weeks old.
- ◆ Growing mash is given to birds aged 8-10 weeks until they are 5 months old or when the egg production reaches 10 percent. This mash promotes pullet growth at a rate that is just right to allow the bird to develop its body and internal organs so that it will start to lay at the right time.
- ◆ The bird should not be allowed to get fat during the growing period because this causes poor egg production and high mortality among layers. A good way of preventing fatness among the pullets is to restrict their feed to 85 percent of normal consumption when they are 18-16 weeks old then full fed them at 17-20 weeks of age.
- ◆ Laying mash is given to pullets when they are about to lay (10 percent or until the layers are replaced) or when they reach 19 weeks of age.
- ◆ Wetting the mash or instituting wet mash-feeding at noon during hot days will increase appetite of the birds.

- ◆ Adopt a regular system of feeding because chickens resent abrupt changes in feeding habits that gets reflected in their performance, especially on egg production.

NUTRITION AND FEEDING

Table I. Daily feed requirements of layers (White Leghorn) according to size of bird and number of eggs laid.

Numbers of eggs Per 100 Hens/Day	Body Weight, kg.				Water Requirement
	1.4	1.8	2.3	2.7	
	Feed required/100 birds/day ¹				gal/100 birds
0	5.9	7.2	8.4	9.6	Moderate temperature =5-7 High temperature =7.9
10	6.3	7.6	8.9	10.0	
20	6.7	8.0	9.3	10.4	
30	7.1	8.4	9.7	10.9	
40	7.5	8.8	10.1	11.2	
50	8.0	9.2	10.5	11.6	
60	8.4	9.6	10.9	12.0	
70	8.8	10.0	11.7	12.5	
80	9.2	10.4	11.7	12.8	
90	9.6	10.8	12.1	13.3	
100	10.0	11.2	12.5	13.7	

Table 2. : Minimum nutrient requirements of chicken under Philippine condition.

NUTRIENT	BROILER			EGG TYPE CHICKEN					
	0-2 Chick booster (CB)	2-5 Broiler starter (BS)	5-8 Broiler finisher (BF)	0-2 Chick booster (CB)	2-6 Chick starter (CS)	6-12 Chick grower (CG)	12-20 Pullet developer (PD)	20-42 Laying mash I (LM)	42 Laying mash II (LMII)
Crude protein, %	21.0	20.0	18.0	21.0	18.0	16.0	16.0	16.5-17.0	16.0
Metabolizable Energy, (ME), Kcal/kg	2900.0	2800.0	2750.0	2900.0	2750.0	2700.0	2700.0	2750-2800	2700.0
Lysine. %	1.20	1.00	0.90	1.20	1.00	0.80	0.80	0.70	0.60

Methionine, %	0.45	0.40	0.35	0.45	0.40	0.30	0.30	0.32	0.30
Math + Cyat, %	0.80	0.85	0.72	0.80	0.70	0.70	0.60	0.55	0.50
Calcium, %	1.00	1.00	1.00	1.00	1.00	1.00	1.00	3.50	3.50
Phosphorus, total %	0.70	0.70	0.65	0.70	0.70	0.70	0.65	0.70	0.55
avail., %	0.50	0.45	0.45	0.50	0.50	0.50	0.50	0.50	0.45
Credut fiber, %	<4	<4	<5	<4	<5	<5	<5	<4	<5
Bost/bag 50 kg.	391.00	350.00	329.00	391.00	331.00	307.00	292.00	319.00	

Source: UP Los Baños

Feed Compositions

1. Find the nutritive value of the following rations (Dahomey) using Granaria and check with the requirements.

Ingredients	Chicks	Layers	Broilers
Maize	26.8	29.5	31.5
Sorghum (=Milocorn)	35.0	35.0	35.0
Fishmeal (Peru)	6.0	3.5	4.0
Skimmilk powder	5.0	5.0	5.0
Groundnutcake	21.5	15.0	18.5
Lucernemeal (16-18% cp)	3.0	3.0	3.0
Shells (37% Ca)	1.0	7.0	1.0
Dicalciumphosphate (23% Ca)	1.1	1.4	1.4
Salt	0.3	0.3	0.3
Vitaminconcentrate	0.3	0.3	0.3
	100	100	100

Source: Poultry Nutrition published by Barneveld College.

HEALTH MANAGEMENT

- The most economical and ideal method to control disease is through prevention, which could be achieved by proper management, good sanitation and having an effective vaccination program.
- Disease outbreak can be prevented by instituting the following vaccination program:

Age of Bird	Type of Vaccine to Use	Route of Administration	Remarks
8-10 days	New Castle Disease (NC) or Avian Pest Vaccine	Intranasal	Chicks from unvaccinated parents may be vaccinated as early as 3 days of age.
21-24 days	Fowl Pox Vaccine	Wing web	May not be given in areas where the disease is not common.
26-28 days	NCD	Intranasal or Intramuscular	Check protection to 10-14 days after vaccination. Revaccinate if protection is low.

COMMON DISEASES OF POULTRY

Avian Pest (Newcastle Disease)

Cause Virus

Transmission

- * Direct contact with the nasal and mouth discharges of infected birds
- * Airborne transmission
- * Through mechanical means such as being carried by sparrows (maya), predators, or other birds.
- * Human beings transmit the disease through infected clothes and shoes.

Signs

- * In young birds, gasping, coughing, rattling of the windpipe, hoarse chirping, paralysis, walking backward and circling.

	<ul style="list-style-type: none"> * In adults, coughing, occasional paralysis, abrupt drop in egg production, soft- shelled eggs, greenish watery diarrhea.
Prevention	Vaccination. Consult your veterinarian for a program suited to your operation.
Treatment	<p>There is no treatment for the disease. In case of an outbreak, the following measures could be adopted to minimize its further spread and effect control of the disease.</p> <ul style="list-style-type: none"> * Isolate sick birds quickly- * Quarantine the area by regulating persons entering the disease-affected premises or from other farms as well as from one poultry house to another. * Revaccination of the birds if titer (detected by serological test) is already low. * Thoroughly disinfect the houses and premises. Allow to dries up before occupancy. <ul style="list-style-type: none"> • Bury dead birds dee • ply or bum.

Chronic Respiratory Disease (CRD)

Cause	Mycoplasma organism or pleuropneumonia-like organism (PPLO)
Transmission	<ol style="list-style-type: none"> 1. CRD organism is egg-borne; contracted exposure with infected flock 2. Airborne transmission.
Signs	<ul style="list-style-type: none"> * Tracheal rales, sneezing, coughing watery or sticky discharged from the nostrils. * Foamy exudates in the eyes. * Feed consumption is reduced and the birds lose weight.

Treatment Broad spectrum antibiotics, either by injection or mixed with the feeds or drinking water.

Coccidiosis

Cause Microscopic organisms called Coccidia (Eimeria species) usually occurs in flocks below two months of age.

Transmission

1. When birds pick up or swallow the coccidial organisms.
2. Contaminated feed and water.
3. Indirect contact thru files, human beings and other mechanical means.

Signs

- * Tendency to huddle together in a comer.
- * Decreased feed and water intake and poor weight gain.

Prevention Incorporation of coccidiostat in the feeds or drinking water. Use of sulfa drugs. Most feed companies incorporate this in the feed mixture as indicated in the feed tags.

Mareks Disease

Cause Virus

Transmission Exposure to infected birds or to environment with existing virus, poultry nests and feeders.

Signs

- * Initial symptoms are leg weakness and paralysis of one or both legs.
- * Birds tend to rest on their breast with one leg extended forward and the other backward
- * They could hardly reach the feeders and waterers resulting in dehydration and emaciation which finally causes death.

Prevention	Vaccination with MD vaccine, the most commonly used is the so called Herpes Virus of Turkey (HVT).
Treatment	There is no known treatment for the disease.

Avian Malaria

Cause	Microscopic protozoan parasite
Transmission	Bites of mosquitoes, mechanically by blood transfer as in mass vaccination, caponization and injection.
Signs	<ul style="list-style-type: none"> * Severe anemia (paleness), extreme leg weakness, emaciation and nervous signs like twisting of the head. * The shanks and toes are dry and birds have ruffled feathers. * Greenish-yellow or greenish-white diarrhea.
Prevention	Control of mosquitoes within the premises and houses with effective insecticides, include spraying the breeding places of mosquitoes. Proper drainage of stagnant water.
Treatment	Anti-malarial drops like plasmochin, quinine-hydrochloride and pyrimethamine combinations were found effective. Confer with the veterinarians.

Fowl Pox

Cause	Virus
Transmission	Spread by mosquitoes that feed on pox-infected birds; direct contact, mechanically transmitted by visitors, wild birds and predators.
Signs	<p>There are two forms:</p> <ol style="list-style-type: none"> 1. <i>Dry form</i> - characterized by the formation of black wart-like nodules on the skin of the face, in the region of the comb, wattles and around the eyes, causing the latter to swell and close. There is usually profuse eye discharge.

2. *Wet form* - characterized by the presence of whitish-yellow growth of the pharynx, larynx and windpipe. Because of the growth, there is difficulty in breathing which will result in death due to suffocation.

Prevention	Vaccination with fowl pox vaccines. Control the mosquitoes by spraying with insecticides.
Treatment	There is no effective treatment against the disease. In the wet form, removal of the wart-like growth in the throat usually leads to recovery. In the dry form, the early application of Tincture of iodine directly on the wart-like growth has been found to give beneficial results.

Infectious Coryza (colds or 'sipon')

Cause	Bacterial organism
Transmission	Through the air, direct contact or through contamination of the feed, water equipment.
Signs	<ul style="list-style-type: none">* Swelling of the face and wattles and discharge from the nostrils, which at first is watery, but becomes sticky and with foul odor as the disease progresses.* In laying flock, egg production decreases.
Prevention	Strict sanitation of the farm. Isolate sick birds immediately.
Treatment	Broad spectrum antibiotics applied in feed and water and sulfa preparation are recommended.

Gumboro Disease (IBD)

Cause	Virus Gumboro disease is called "catastrophe disease" because it is the principal cause of catastrophe in flock. The latter is a term applied to flocks with high losses from variable disease conditions.
Transmission	By contact from bird to bird, contaminated persons or clothing of caretaker.

Signs	Pure cases of IBD infection are difficult to recognize. Slight tremors of the neck and the body, depression, ruffled feathers, wet- droppings, loss of appetite, severe prostrations and few deaths are clinical manifestations. However, the disease should be suspected when an unacceptable percentage of morbidities and mortalities occur between 3-13 weeks of age, these high losses being associated with vaccination reaction in gangrenous dermatitis (wing rot) and anemia.
Prevention	Vaccination using IBD vaccine (Bursa- Vac-Sterwin).
Control	Immediately isolate the flock in affected houses and control tile entry of caretakers, egg collectors, supervisory personnel and vehicles. Remove and destroy affected birds immediately. Incinerate dead birds.
Treatment	While there is no successful method of treatment known, improving tile nutritional quality of tile feeds (conditioning rations) and a therapeutic antibiotic regimen to check possible emergence of secondary bacterial infection must be instituted. Stresses should be avoided.

MARKETING

Marketing of Broilers

1. For Contract Growers

- * Birds that have attained the marketable weight should be sold. Birds should be harvested as scheduled. When harvest schedule approaches, the company's representative should be reminded of the exact date that birds are to be harvested and the assurance that his company trucks should come on time. This is to ensure that the birds will not consume extra feeds due to longer stay in the farm without any beneficial effect to the grower.
- * The birds should be harvested within the shortest possible time. There are companies that sell to viajeros. The middlemen tend to select the

bigger and healthier birds of relatively uniform sizes. This practice should not be allowed since this will disturb the other birds resulting to weight losses and also delays the harvesting.

2. For Independent Growers

- * Alternative market outlets should be surveyed even before deciding to broilers to be assured of a ready market at the time of harvest. Marketing arrangements with local hotels, restaurants, cafeterias, institutional buyers and grocery stores with freezers should be made.
- * Producers should form associations or market cooperatives so that they could agree on a common price. Organized producers have some bargaining power with regard to their selling prices-
- * Producers will be best advised to compute which is more profitable to sell, the birds dressed or live, and whether to sell at the farm or bring them to market.
- * The broilers should be sold at optimum weight. More profits can be derived if broilers are sold between 1.3 to 1.5 kg. live weight depending on consumers preferences and market reports.

Marketing of Eggs

- * Survey market outlets before investing in egg production. Marketing arrangements must be made with local bakeries, local hotels, restaurants, cafeterias, groceries, or sari-sari stores, higher income families and other regular users. This will ensure regular orders for the eggs.
- * Sell graded or classified eggs. Proper grading or classification can attract all types of consumers. This would also enable the consumers to make purchasing decisions on the egg size at hand.
- * Sell only clean eggs since everybody wants clean eggs. Dry or wet cleaning of eggs should be a standard practice on the farm.
- * Reduce breakage and spoilage of eggs to the minimum. Broken eggs constitute losses and render the container unsightly.

INPUTS IN PRODUCTION

Broiler Production -Prospective investors should consider the following before going into the venture blindly.

Costs

Housing and brooder facilities

Day-old broiler chicks

Broiler feeds

Veterinary vaccines, medicines and supplements

Water

Heat and light

Labor

Depreciation

Interest on capital invested

Returns

Sales of broilers

Sale of chicken manure to vegetable growers or fishpond owners

Sale of good-condition empty feed bags

Egg Production -As in tile broiler production the same capital outlays apply such as:

Costs

Housing and brooding facilities

Day-old chicks

Starter mash

Grower mash

Layer mash

Vaccines, medicines and supplements

Heat and light

Water

Labor

Depreciation

Interest on capital invested

Chicken Broiler Production

A. Cost of Production: (1000 per cooperators)

Assumptions:

Cost of day-old chick P 20.00/hd	P20,000.00
Growing period -42-45 fsysd	
Target weight, kgs -1.6 kg	
Mortality -4%	
Feed Consumption	
Chick Booster 10g/hd/day for 7 days	
@ p 14.40/kg	P 1,080.00
Broiler Starter 60g/day for 3 wks	
@ p 11.50/kg	P14,490.00
Broiler Finisher 90g/day for 2 weeks	
@ P 10.55/kg	P13,293.00
Sub-total	P28,863.00
Other Expenses:	
Medicines P 1.00/chick	P 1,000.00
Miscellaneous 1.50/chick	P 750.00
Sub-total	P 1,750.00
Housing Cooperator's equity	

B. Income Computation:

Total Sales 960 x 1.6 kg@ P70/kg	P 107,520.00
Plus other Income	P 600.00
Total Income	P 108,120.00
Less: Total Expense	P 50,613.00
Gross Income	P 57,507.00

GLOSSARY

- Brooding* - pag-aalaga ng sisiw sa pamamagitan ng "artificial heat".
- extremes in temperature* - sobrang lamig o sobrang init ng panahon.
- feed efficiency* - ang dami o kilo ng patuka na makapagbibigay ng isang kilong timbang na produkto:
- feed spillage* - pagtapon o aksaya ng patuka sa patukaan.
- high livability* - maraming nabubuhay na sisiw.
- production capacity* - maaaring tumukoy sa bilang ng manok na maaaring alagaan sa isang partikular ng laki ng kulungan o di kaya maaaring tumukoy sa bilang ng manok na maaani ng isang manukan sa isang taon.
- productive life* - tumutukoy sa haba ng panahon na ang manok ay makakapan-gitlog ng marami.
- stress* - tensyon o kaya mga bagay-bagay na nagpapahirap sa manok.
- ventilation* - tumutukoy sa kaalwanan ng isang kulungan dahil sa pagpasok ng sariwang hangin o kaya paglabas ng gamit na o masamang hangin.

SOURCES

The Philippine Recommends for Broiler Production

Maunlad na Pagmamatlukan-LDC Bulletin

Poultry Raising Guide by B-Meg

Poultry Raising

For further reading consults Rufino Gapuz Book on Poultry Raising and Francisco Fronda Book on Poultry Science